

> CMP² - CMP² HE

CONDENSING UNITS
FOR INDOOR INSTALLATION



Available range

Unit type

- SR Condensing unit
- SP Reversible condensing unit
(reversible on the refrigerant side)

Versions

- VB Base Version

Acoustic setting up

- AB Base setting up
- AS Low noise setting up

Unit description

This series of condensing units satisfies the cooling and heating requirements of residential plants of small and medium size.

All the units are suitable for indoor installation and can be connected to a remote heat exchanger properly designed in order to transfer to the plant all the cooling (and heating for reversible units) power generated.

It is possible for example to connect direct expansion coils placed inside air handling units or remote plate heat exchangers placed inside technical rooms. In both cases the lack of outdoor hydraulic pipes eliminates the freezing problems and avoids brine solutions to be used.

The refrigerant circuit, contained in a compartment protected from the air flow to simplify the maintenance operations, is

equipped with scroll compressor mounted on damper supports, centrifugal fans (plug fan), finned coil made of copper pipes and aluminium louvered fins and shut off valves on the liquid line and on the gas line. The reversible units are moreover supplied with reverse cycle valve, thermostatic expansion valve (working in heating mode) and liquid receiver.

The circuit is protected by high and low pressure switches.

All the units are equipped with variable speed fans control that allows the units to operate with low outdoor temperatures in cooling and high outdoor temperature in heating and permits to reduce noise emissions in such operating conditions.

The low noise acoustic setting up (AS) is obtained, starting from the base setting up (AB), reducing the rotational speed of the fans and mounting sound jackets on the compressors.

All the units are supplied with an outdoor temperature sensor, already installed on the unit, in order to realize the climatic control.

All the units are provided with a phase presence and correct sequence controller device.

All the units are accurately built and individually tested in the factory.

All the units are supplied with refrigerant charge inside.

Only electric and refrigerant connections (between condensing unit and remote heat exchanger) are required for installation.

Options

Compressor starting

- standard (contactors)
- soft starter

Electrical loads protection

- fuses
- thermal magnetic circuit breakers

Compressor power factor correction

Accessories

Rubber vibration dampers

Coil protection grille

Remote control

Modbus serial interface on RS485

Programmer clock

Phase sequence and voltage controller

Remote plate heat exchanger

Liquid line

NET NOMINAL performances - CMP²

SR	Base setting up (AB)	19.1	22.1	26.1	30.1	35.1	40.1	
A35E5	Cooling capacity	21,4	24,2	28,0	32,9	37,7	43,8	kW
	Power input	6,75	7,53	8,67	10,66	11,99	13,85	kW
	EER	3,17	3,21	3,23	3,08	3,14	3,17	W/W
SR	Low noise setting up (AS)	19.1	22.1	26.1	30.1	35.1	40.1	
A35E5	Cooling capacity	20,5	23,2	26,9	31,6	36,2	42,1	kW
	Power input	7,26	8,14	9,34	11,45	12,97	14,92	kW
	EER	2,83	2,85	2,88	2,76	2,79	2,82	W/W
SP	Base setting up (AB)	19.1	22.1	26.1	30.1	35.1	40.1	
A35E5	Cooling capacity	20,9	23,5	27,2	32,0	36,7	42,8	kW
	Power input	6,82	7,65	8,76	10,78	12,12	14,00	kW
	EER	3,06	3,07	3,11	2,97	3,02	3,06	W/W
A7C50	Heating capacity	20,0	22,5	26,1	30,9	35,5	40,1	kW
	Power input	6,87	7,71	8,95	11,07	12,42	13,97	kW
	COP	2,91	2,92	2,92	2,79	2,86	2,87	W/W
A7C45	Heating capacity	22,0	24,8	28,8	34,1	39,1	44,2	kW
	Power input	6,05	6,79	7,88	9,76	10,88	12,25	kW
	COP	3,64	3,66	3,66	3,50	3,60	3,61	W/W
SP	Low noise setting up (AS)	19.1	22.1	26.1	30.1	35.1	40.1	
A35E5	Cooling capacity	20,0	22,6	26,2	30,7	35,2	41,0	kW
	Power input	7,32	8,23	9,41	11,54	13,09	15,05	kW
	EER	2,73	2,74	2,79	2,66	2,69	2,72	W/W
A7C50	Heating capacity	18,9	21,4	24,9	29,6	33,8	38,2	kW
	Power input	6,63	7,41	8,61	10,66	12,02	13,40	kW
	COP	2,85	2,89	2,89	2,77	2,81	2,85	W/W
A7C45	Heating capacity	20,9	23,6	27,5	32,6	37,3	42,2	kW
	Power input	5,84	6,52	7,59	9,39	10,58	11,88	kW
	COP	3,58	3,62	3,62	3,47	3,52	3,55	W/W

NET NOMINAL performances - CMP² HE

SR	Base setting up (AB)	19.1	22.1	26.1	30.1	35.1	40.1	
A35E5	Cooling capacity	22,3	24,9	29,0	34,9	39,6	46,2	kW
	Power input	6,12	6,83	7,83	9,52	10,84	12,46	kW
	EER	3,63	3,65	3,70	3,66	3,65	3,71	W/W
SR	Low noise setting up (AS)	19.1	22.1	26.1	30.1	35.1	40.1	
A35E5	Cooling capacity	21,4	23,9	27,9	33,6	38,1	44,6	kW
	Power input	6,62	7,38	8,47	10,29	11,61	13,21	kW
	EER	3,24	3,23	3,29	3,26	3,29	3,38	W/W
SP	Base setting up (AB)	19.1	22.1	26.1	30.1	35.1	40.1	
A35E5	Cooling capacity	21,8	23,8	27,8	33,6	39	44,1	kW
	Power input	6,07	7,03	8,16	10,1	11,7	13,2	kW
	EER	3,60	3,39	3,4	3,34	3,33	3,33	W/W
A7C50	Heating capacity	20,5	23,2	27,0	31,8	36,5	42,4	kW
	Power input	6,46	7,13	8,21	10,01	11,40	12,91	kW
	COP	3,18	3,26	3,29	3,17	3,20	3,29	W/W
A7C45	Heating capacity	22,7	25,6	29,8	35,1	40,2	46,8	kW
	Power input	5,69	6,28	7,23	8,78	10,04	11,44	kW
	COP	3,98	4,08	4,12	3,99	4,01	4,09	W/W
SP	Low noise setting up (AS)	19.1	22.1	26.1	30.1	35.1	40.1	
A35E5	Cooling capacity	20,9	23,8	27,8	33,6	39	44,1	kW
	Power input	6,55	7,03	8,16	10,1	11,7	13,2	kW
	EER	3,20	3,39	3,4	3,34	3,33	3,33	W/W
A7C50	Heating capacity	19,5	22,1	25,9	30,4	34,6	40,4	kW
	Power input	6,24	6,91	7,95	9,64	10,98	12,51	kW
	COP	3,12	3,19	3,25	3,15	3,16	3,23	W/W
A7C45	Heating capacity	21,5	24,3	28,5	33,6	38,3	44,6	kW
	Power input	5,50	6,09	7,00	8,50	9,71	11,03	kW
	COP	3,91	3,99	4,08	3,96	3,95	4,05	W/W

The values are referred to units without options and accessories.

EER (Energy Efficiency Ratio) = ratio of the total cooling capacity to the effective power input of the unit

COP (Coefficient Of Performance) = ratio of the total heating capacity to the effective power input of the unit

A35E5 = source : air in 35°C d.b. / plant : evaporation temperature (dew point) 5°C - superheating 5°C

A7C50 = source : air in 7°C d.b. 6°C w.b. / plant : condensation temperature (dew point) 50°C - subcooling 5°C

A7C45 = source : air in 7°C d.b. 6°C w.b. / plant : condensation temperature (dew point) 45°C - subcooling 5°C

Acoustic performances

Base setting up (AB)	19.1	22.1	26.1	30.1	35.1	40.1	
Sound power level	76	76	77	80	81	81	dB(A)
Sound pressure level at 1 meter	60	60	61	64	65	65	dB(A)
Sound pressure level at 5 meters	50	50	51	54	55	55	dB(A)
Sound pressure level at 10 meters	45	45	46	49	49	50	dB(A)
Low noise setting up (AS)	19.1	22.1	26.1	30.1	35.1	40.1	
Sound power level	74	74	75	78	79	79	dB(A)
Sound pressure level at 1 meter	58	58	59	62	63	63	dB(A)
Sound pressure level at 5 meters	48	48	49	52	53	53	dB(A)
Sound pressure level at 10 meters	43	43	44	47	47	48	dB(A)

The acoustic performances are referred to units operating in cooling mode at nominal conditions A35E5.

Unit placed in free field on reflecting surface (directional factor equal to 2).

The sound power level is measured according to ISO 9614 standard.

The sound pressure level is calculated according to ISO 3744 and is referred to a distance of 1/5/10 metres from the external surface of the unit.

Technical data

Unit	19.1	22.1	26.1	30.1	35.1	40.1	
Power supply	400 - 3N - 50						V-ph-Hz
Compressor type	scroll						-
N° compressors / N° refrigerant circuits	1 / 1						n°
Source side heat exchanger type	finned coil						-
Fans type	centrifugal (plug fan)						-
N° fans	1						n°
Tank volume	5/8"						-
Hydraulic fittings	1" 1/8						-

Electrical data

Standard unit	19.1	22.1	26.1	30.1	35.1	40.1	
FLA - Full load current at maximum tolerated conditions	28,9	30,9	33,0	28,0	32,0	36,1	A
FLI - Full load power input at maximum tolerated conditions	13,0	14,3	15,6	16,8	19,4	22,0	kW
MIC - Maximum instantaneous current of the unit	108	124	131	131	146	180	A
MIC SS - Maximum instantaneous current of the unit with soft starter options	65	74	78	75	84	104	A

Operating range

Temperature	Unit type	Cooling		Heating		
		min	max	min	max	
Outdoor air inlet temperature	SR, SP	-10	48 (STD) 50 (HE)	-15	42	°C
Evaporating temperature (dew point)	SR, SP	0	15	-	-	°C
Condensing temperature (dew point)	SP	-	-	30	60	°C

CONTROL SYSTEM

The unit is managed by a microprocessor controller to which, through a wiring board, all the electrical loads and the control devices are connected. The user interface is realized by a display and four buttons that allow to view and, if necessary, modify all the operating parameters of the unit. It's available, as an accessory, a remote control that reports all the functionalities of the user interface placed on the unit.

The main functions available are :

- water or air temperature management (through set point adjustment)
- adaptive function
- climatic control in heating and in cooling mode (automatic set point adjustment according to outdoor air temperature)
- dynamic defrost cycle management according to outdoor air temperature
- alarm memory management and diagnostic

- fans management by means of continuous rotational speed control
- pump or fan management on the plant side
- integrative electrical heaters management in heating mode (2 step logic)
- compressor and pump or fan operating hours recording
- serial communication through Modbus protocol
- remote stand by
- remote cooling-heating
- general alarm digital output



DIMENSIONS AND MINIMUM OPERATING AREA

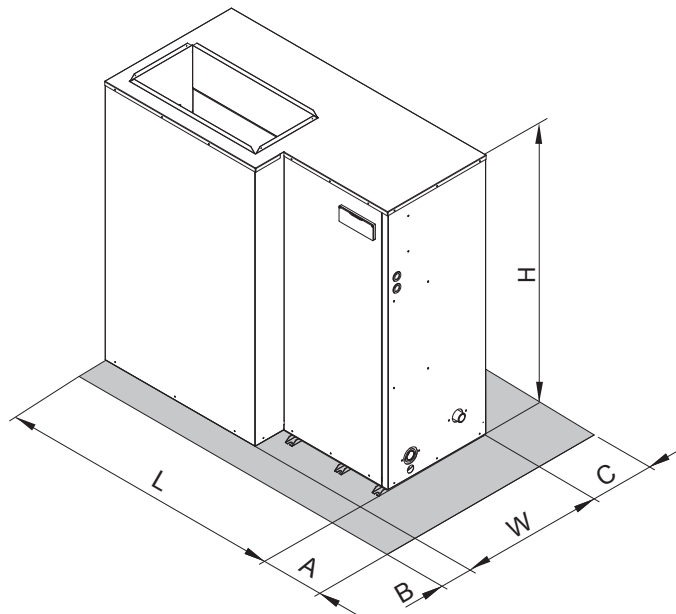

	19.1	22.1	26.1	30.1	35.1	40.1	
L	1494	1494	1494	1704	1704	1704	mm
W	744	744	744	744	744	744	mm
H	1453	1453	1453	1453	1453	1453	mm
A	400	400	400	400	400	400	mm
B	450	450	450	450	450	450	mm
C	200	200	200	200	200	200	mm
CMP unit - maximum weight operation	256	259	274	278	298	300	kg
CMP HE unit - maximum weight operation	271	274	294	303	323	325	kg